

INSTALLATION INFORMATION
(PER MACHINE)

ELECTRICAL REQUIREMENT: 230/460 VOLT 380 VOLT
60 HZ 50 HZ
6.0/3.0 AMP 3.3 AMP

AIR REQUIREMENT: 1.0 SCFM
80 PSI (MIN)

WATER REQUIREMENT: 1.0 GPM
40 PSI (MIN)

MACHINE WEIGHT: 1000 LBS (APPROX.)

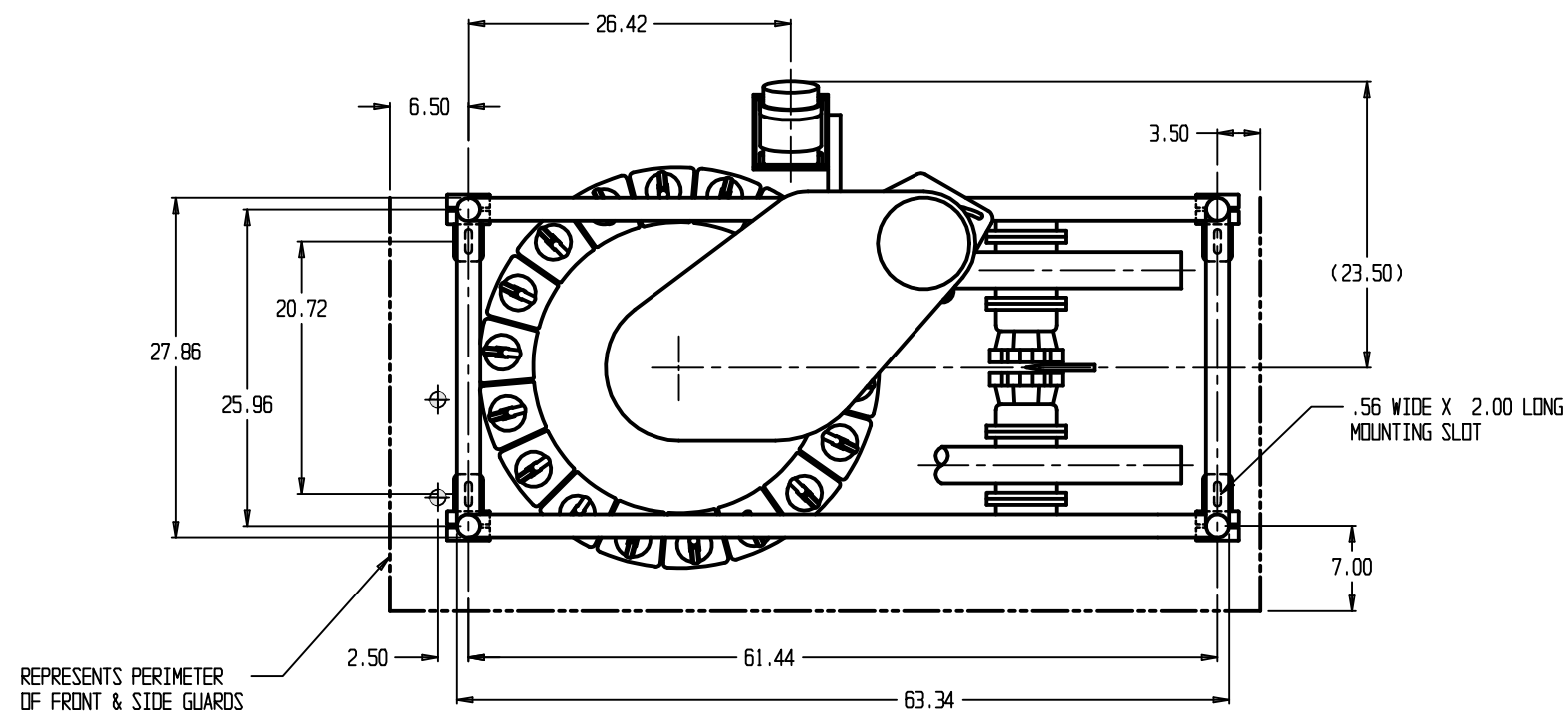

REV	REV NO	DESCRIPTION	DR	DATE
-	*	REVISED LAYOUT & ADDED INSTALLATION INFORMATION	DRL	4-15-98
-	*	(23.50) WAS 24, 0526.0006 WAS 526-4, 0537.0021 WAS 537-21, (12") WAS 12", ADD 3"-5", 3.75 WAS 3.57, REMOVED (27 TO 32), 26 TO 29 WAS 25 TO 28	DRL	5-7-98
-	*	ADDED 230 VOLT/6.3 AMP, ADDED 3-WAY HOPPER, NOTES 1 & 2, ADDED GUARD PERIMETER NOTE, ADDED ELECTRICAL BOX, 6.50 WAS (6.0) MOVED WATER & AIR INLETS 52.00 WAS 54.00 ADDED 12.13, 13.50 WAS (13), 2.77 WAS 2.69	DRL	6-3-99
-	*	ADDED NOTE 3	DRL	02-21-01
-	*	(60HZ) 6.0/3.0 AMP WAS 6.3/3.3 AMP, 80 PSI MIN WAS 100 PSI, 1.0 GPM WAS 1.5 GPM ADDED 380 VOLT 50 HZ 3.3 AMP	DRL	7-30-01
A	20977	ADDED SHEET 2	BR	24SEPT02

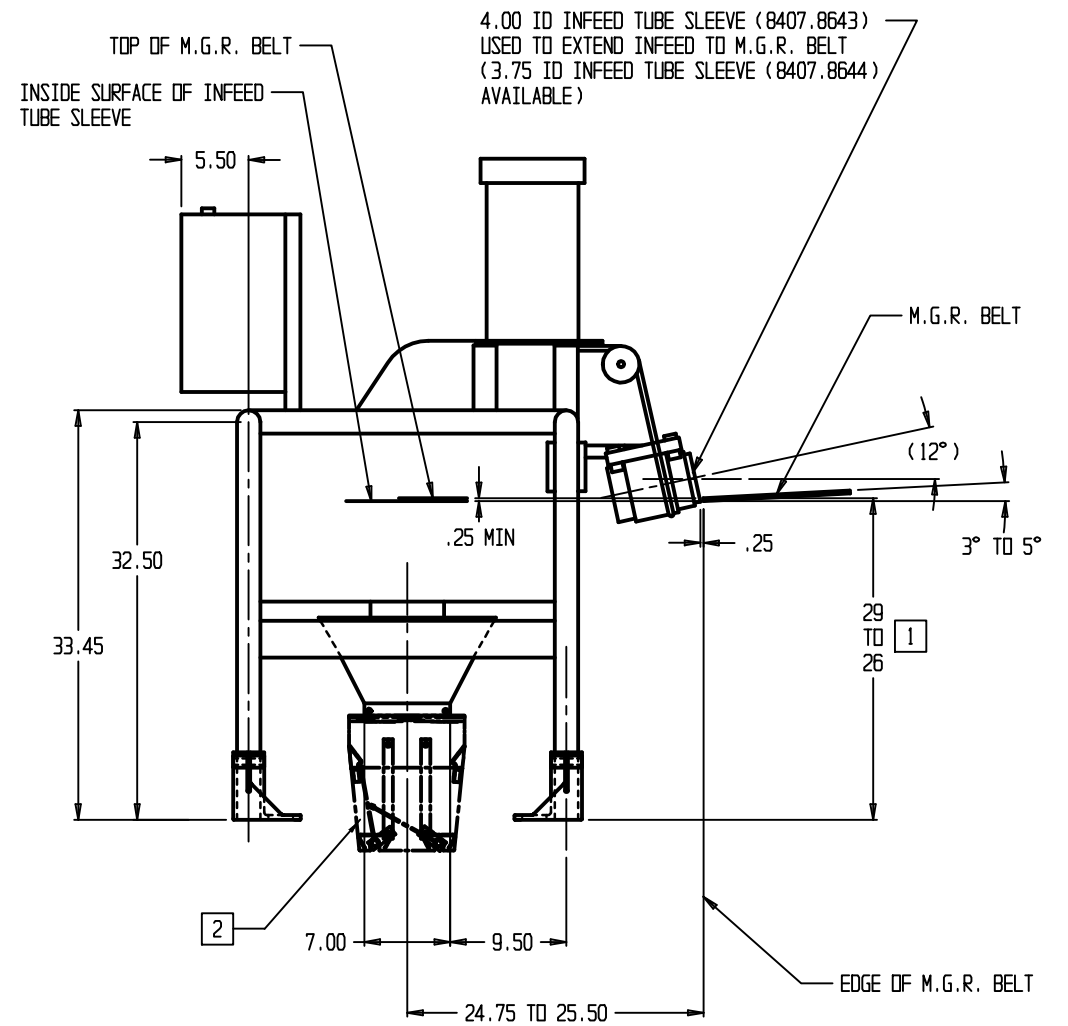
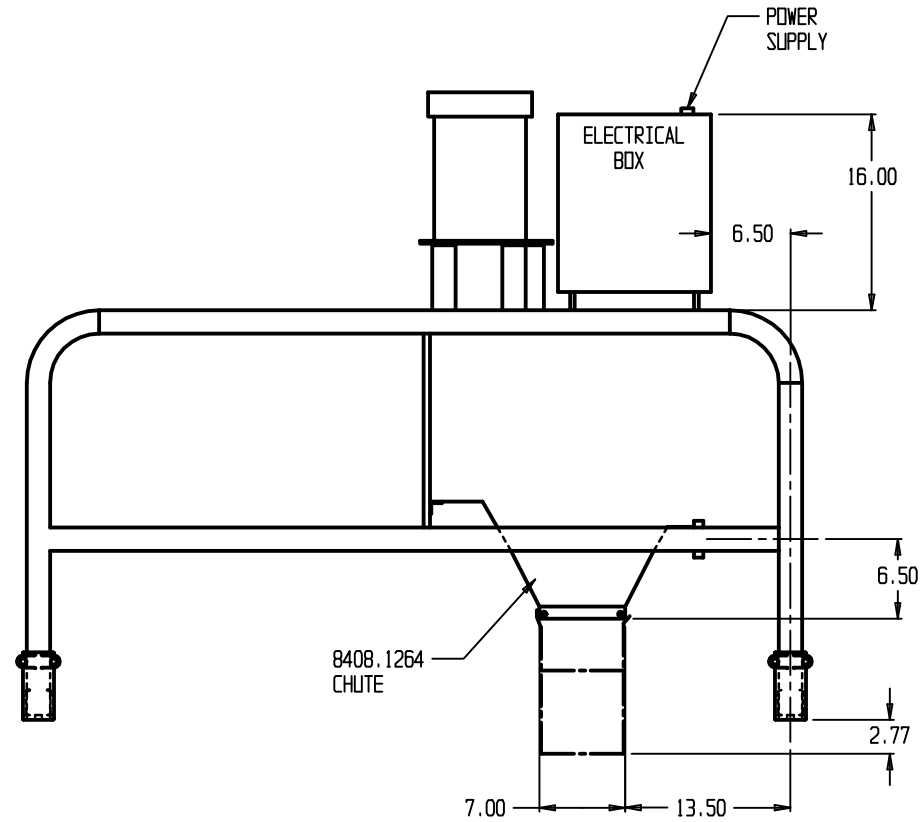
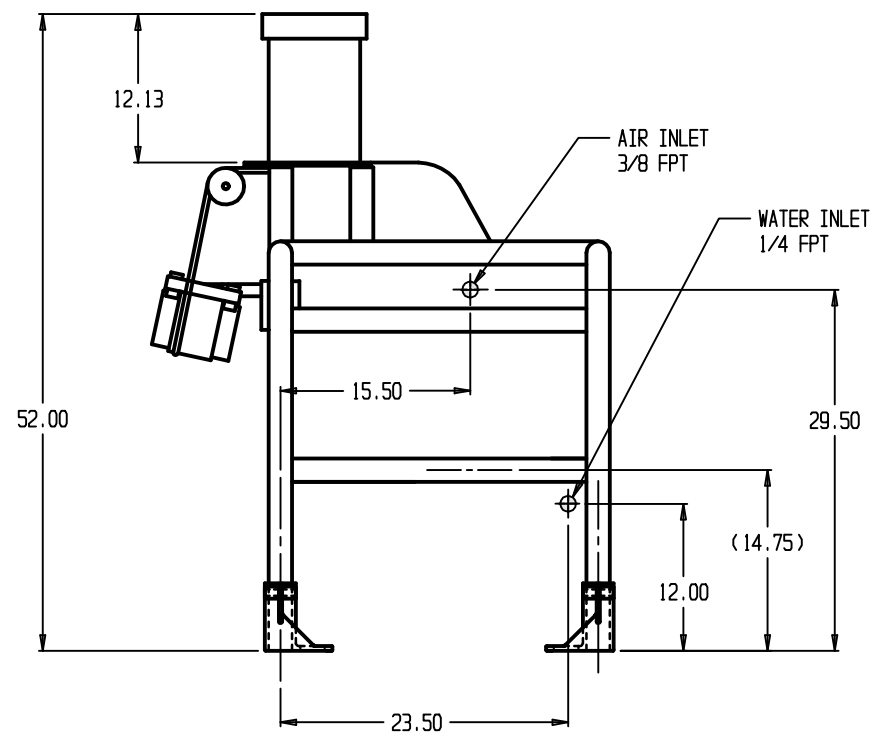

3. INSTALLATION KIT P/N 8408.1310 (INCLUDES MOUNTING HARDWARE, FITTINGS, AND TUBING FOR BOTH AIR AND WATER SUPPLY)

2. OPTIONAL 3-WAY HOPPER

1. 26 TO 29 INCH DIMENSION REPRESENTS TOP CORNER EDGE OF MGR BELT. ALL MACHINE HEIGHT DIMENSIONS ARE BASED ON 26 INCH MGR BELT HEIGHT.

NOTES:

WHERE USED	QTY	ITEM	QTY	PART NUMBER	MATERIAL/DESCRIPTION
N/A	-	-	-	N/A	N/A
UNLESS OTHERWISE SPECIFIED					
PARTS LIST					
CLEAN PITTER LAYOUT					
FILE NO. 8407-9693.01A	TITLE				
REV. REVISION N/A	DESIGNER D. LAYDON	DATE 4-15-98			
DRAWN N/A	PRODUCTION RELEASE	SCALE 1/8	SHEET 1 OF 2	SIZE D	REV A
<p>THIRD ANGLE PROJECTION</p> <p>PROPRIETARY INFORMATION NOTICE THIS DRAWING CONTAINS PROPRIETARY AND CONFIDENTIAL INFORMATION WHICH SHALL NOT BE REPRODUCED, COPIED, OR USED FOR ANY PURPOSE OTHER THAN THAT FOR WHICH IT WAS ORIGINALLY INTENDED WITHOUT THE WRITTEN PERMISSION OF ATLAS PACIFIC ENGINEERING CO., INC.</p>					

PART NO. 8407.9693

REVISIONS			
REV	REV NO	DESCRIPTION	DATE
-	-	SEE SHEET 1	-

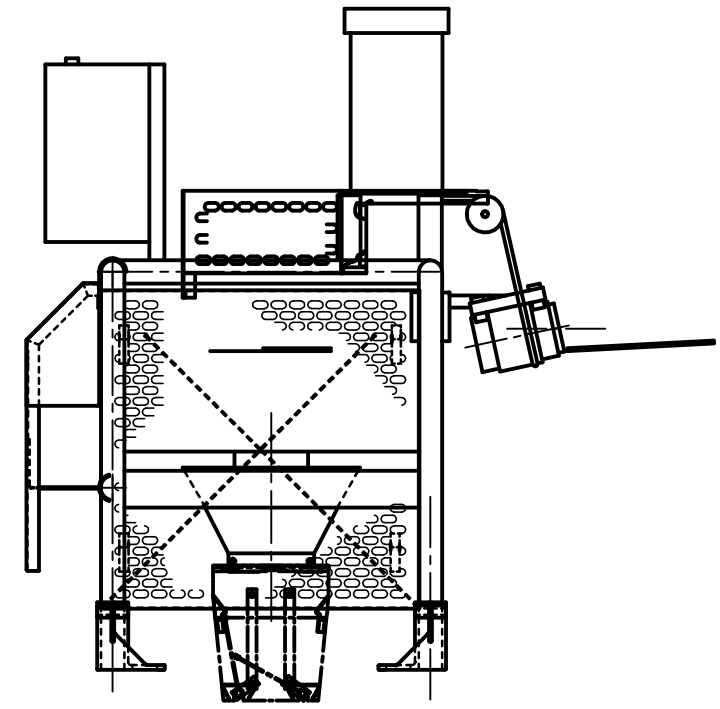
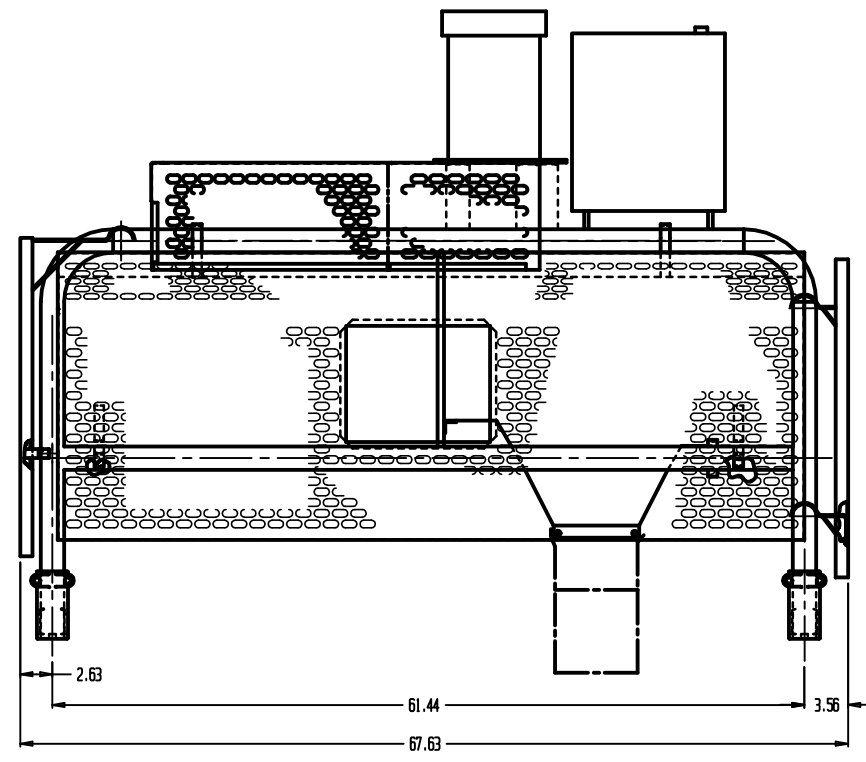
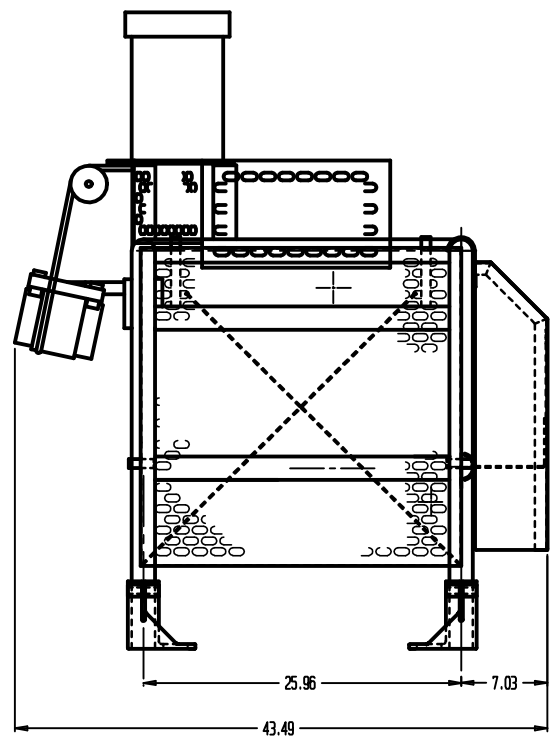
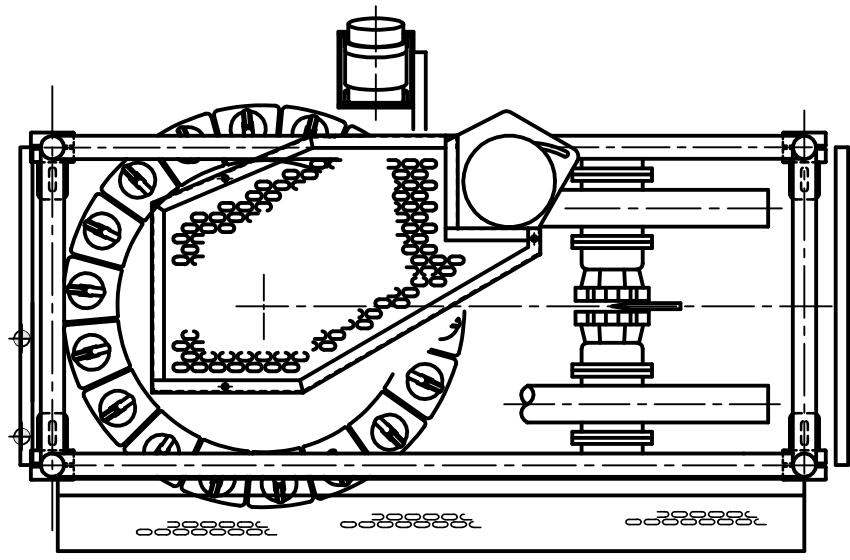

WHERE USED	QTY	ITEM	QTY	PART NUMBER	MATERIAL/DESCRIPTION
UNLESS OTHERWISE SPECIFIED					
PARTS LIST					
CLEAN PITTER LAYOUT					
PRICE NO. 8407-9693.D2A		PROGRAM BR	DATE 24SEPT02		
NEXT REVISION N/A		DESIGNER BR	DATE 24SEPT02		
FINISH N/A		<small>PROPRIETARY INFORMATION NOTICE</small> <small>THIS DRAWING CONTAINS PROPRIETARY AND CONFIDENTIAL INFORMATION WHICH SHALL NOT BE REPRODUCED, DISCLOSED TO OTHERS, COPIED, OR USED FOR ANY PURPOSE OTHER THAN THAT FOR WHICH IT WAS PREPARED WITHOUT THE WRITTEN PERMISSION OF ATLAS PACIFIC ENGINEERING CO., A DIVISION OF</small>			<small>SCALE</small> 1/8
THIRD ANGLE PROJECTION				<small>SIZE</small> D	<small>REV</small> A
				<small>SHEET</small> 2 OF 2	<small>PART NUMBER</small> 8407.9693

PART NO. 8407.9693
 SHEET 2 OF 2
 REV A